



SERVICE LETTER No. L 120

DATE: March 4, 2019

TO: **Sault College Aviation Technology**

MODELS AFFECTED: **Z 242 L aircraft, S/N 0743, 0744**

SUBJECT: **Operation limits – Increase of safe life limit to 11 000 flight hours**

According to analysing the data from the AMU 1, with respect to actual:

- kind of operation,
- number of flight hours,
- number of landings,
- approved safe life limits for aircraft parts,

we determine as follows:

The aircraft can be operated **up to total safe life limit of 11 000 flight hours** according to special limits and instructions stated in the report Z242L-0576. Number of flight hours shall be calculated according to Aircraft Journey Log Book.

Recalculation of number of flight hours with respect to a difference between Aircraft Journey Log Book and AMU 1 records might be possible after final AMU 1 records evaluation in the end of aircraft safe life.

.....
Prof. Ing. Antonín Pištěk, CSc.
Head of Office of Airworthiness

Z 242L Assessment Report - Aircraft Safe-life prolongation up to 11 000 flight hours Sault College Aviation Technology

(Z 242L, S/N 0743 and Z 242L, S/N 0744)



Prepared by:

T. Belohradsky
Stress Analysis Department

A blue ink signature of T. Belohradsky, consisting of a stylized 'T' and 'B' followed by a horizontal line.

Approved by:

L. Januska
Head of DOA

A blue ink signature of L. Januska, featuring a stylized 'L' and 'J' followed by a horizontal line.

A. Pistek
Head of Office of Airworthiness

A blue ink signature of A. Pistek, showing a stylized 'A' and 'P' followed by a horizontal line.

Date of issue: 04.03.2019
Number of pages: 32
Number of Appendices: 2

Issue No: 1



CONTENT

CONTENT	2
MARKING USED	4
1 INTRODUCTION	5
2 Z 242L AIRCRAFT	6
2.1 BRIEF DESCRIPTION OF THE Z 242L AIRCRAFT	6
2.2 CONSIDERED SPECTRUM OF Z 242L AIRCRAFT LOADING	8
3 SAFE FATIGUE LIFE OF THE Z 242L AIRCRAFT	11
3.1 THE FATIGUE TEST OF THE WING MADE BASED ON ZLIN-A AND ZLIN-N LOADING SPECTRA	11
3.2 RESULTS OF FATIGUE TESTS OF THREE MAIN WING SPARS OF THE Z 242L AIRCRAFT AT THE CAA-FAA LOAD SPECTRUM	11
4 SAFE FATIGUE LIFE OF THE WING	12
4.1 STRESS VALUES IN CRITICAL SECTION A-A (CATEGORY U)	14
4.2 STRESS VALUES IN CRITICAL SECTION A-A (CATEGORY N)	14
4.3 SAFETY FACTOR DETERMINATION	15
4.4 SAFE FATIGUE LIFE CALCULATION FOR CANADA-OPERATION LOADING SPECTRUM	15
5 SAFE FATIGUE LIFE OF MAIN SPAR OF THE FUSELAGE FRAME	16
5.1 STRESS VALUES IN CRITICAL SECTION A-A (CATEGORY U)	18
5.2 STRESS VALUES IN CRITICAL SECTION A-A (CATEGORY N)	18
5.3 SAFETY FACTOR DETERMINATION	19
5.4 SAFE FATIGUE LIFE CALCULATION FOR ENVELOPE LOADING SPECTRUM	19
5.5 SAFE FATIGUE LIFE DETERMINATION OF THE FUSELAGE FRAME MAIN SPAR	19
6 SAFE FATIGUE LIFE OF THE REAR PART OF THE FUSELAGE AND BOLTS /Z42.1300-00.11/, CONNECTING CENTRAL AND REAR PART OF THE FUSELAGE	20
7 SAFE FATIGUE LIFE OF TAIL SURFACES	22
8 SAFE FATIGUE LIFE OF ENGINE MOUNT	23
9 REGULAR REPLACEMENTS OF PARTS OF THE Z 242L AIRCRAFT	24
10 AIRCRAFT PARTS AT WHICH OVERHAUL IS MADE	24
11 INSTRUMENTS AND AGGREGATES	24
12 OPERATION INFORMATION ANALYSIS	24
13 CONCLUSION	25



APPENDIX NO. 1	26
TECHNICAL COMMISSION REPORT BASED ON THE REQUEST TO INCREASE THE OPERATIONAL LIFE TIME UP TO 11 000 FLIGHT HOURS (S/N 0743)	26
APPENDIX NO. 2	29
TECHNICAL COMMISSION REPORT BASED ON THE REQUEST TO INCREASE THE OPERATIONAL LIFE TIME UP TO 11 000 FLIGHT HOURS (S/N 0744)	29
LITERATURE	32

MARKING USED

FAR Part 23	Federal Aviation Regulations for Small Airplanes, USA	
AFS-120-73-2	FAA Fatigue Evaluation of Wing and Associated Structure on Small Airplanes	
AC23-13A	FAA Advisory circular for fatigue analyses and tests	
AMU1	Acceleration Monitoring Unit	
SFL	Safe Fatigue Life	
FAA	Federal Aviation Administration of the USA	
CAA	Civil Aviation Authority of the Great Britain	
ZLIN-A	Measured operating loading spectrum for acrobatic category	
ZLIN-N	Measured operating loading spectrum for normal category	
CAA-FAA	CAA operation acrobatic spectrum for the Z 40 series, modified FAA	
ENVELOPE	Safe envelope of loading spectrum Canada-Operation	
SCAT	Sault College Aviation Technology	
S-N curve	Fatigue curve (Wöhler curve)	
n	[-]	Load factor according to the FAR 23
σ_{+1g}	[MPa]	Stress in flight at $n = +1(g)$
σ_{-1g}	[MPa]	Stress at the ground stay $n = -1(g)$
D_i	[1/hod]	Fatigue damage in individual phases of flight
D_C	[1/hod]	Total fatigue damage
L_B	[hod]	Safe fatigue life value
L_S	[hod]	Mean fatigue life value
j_N	[-]	Scatter factor
V_P	[km/h]	Average airspeed

1 INTRODUCTION

The Sault College Aviation Technology (SCAT) operates a fleet of 10 ZLIN Z 242L aircraft. The list of aircraft is available in the Table No.1-1 below.

Type [-]	S/N [-]	Reg. mark [-]	Flight hrs. (02/2019) [Hrs]	Landings (02/2019) [-]	Monitored by AMU1 [Hrs]	Acro (A) [Hrs]	Acro (U) [Hrs]	Acro (A+U) [Hrs]	Safe-life limit [%]	
Z 242L	0679	C-FQHT	Out of operation							
Z 242L	0681	C-FANU	14390:24	13797	5141:30:00	–	–	–	35.32 %	
Z 242L	0682	C-FHTU	15890:48	15208	9772:45:00	–	–	–	26.53 %	
Z 242L	0683	C-FVWH	Out of operation							
Z 242L	0684	C-FCSB	15990:54	15475	11665:06:00	–	–	–	23.08 %	
Z 242L	0685	C-FVWT	15190:12	14470	10522:20:00	–	–	–	32.62 %	
Z 242L	0699	C-FZHF	2690:30	2493	2079:54:00	–	–	53:54:00	73.74 %	
Z 242L	0742	C-GHXG	11598:00	10994	11180:24:00	–	–	–	63.96 %	
Z 242L	0743	C-GHXG	4993:18	4487	3806:18:00	–	–	126:00:00	76.89 %	
Z 242L	0744	C-GERR	4598:00	4162	4345:45:00	–	–	–	79.82 %	
Z 242L	0745	C-GHXF	10491:06	9810	10078:18:00	–	–	–	66.10 %	
Z 242L	0746	C-GJOR	11095:06	10422	10578:06:00	–	–	–	58.83 %	

Table No. 1-1 ZLIN Z 242L operated by Sault College Aviation Technology

The basic operational life of the Z 242L aircraft is 5500 flight hours. The aircraft are monitored by the acceleration monitoring unit AMU1. Based on the AMU1 monitoring a new operational limit has been set in the year 2003 by the Report No. Z242L-0554, [1]. The operational limit was increased from 5500 to 11000 flight hours.

At present days the aircraft Z 242L, S/N 0743 and S/N 0744 are reaching the operational limit 5500 flight hours. The aim of this assessment report is to prove Safe Fatigue Life (SFL) of aircraft primary structure up to 11000 flight hours for aircraft Z 242L, S/N 0743 and S/N 0744 operated in aviation school Sault College Aviation Technology in Canada. The long times monitoring by AMU1 system is used as an input source for the aircraft prolongation.

2 Z 242L AIRCRAFT

2.1 Brief description of the Z 242L aircraft

The Z 242L aircraft (Fig. 2-1) is designed in the category A, U and N according to FAR Part 23 -Amdt. 23-36 inclusive.

The Z 242L aircraft is intended for basic and advanced training, acrobatic training and practice, practice in night and instrument flying and glider towing.

The Z 242L aircraft is a two-seats, low-wing, single engine, self-supporting monoplane of all metal structure with side by side seats. The aircraft is equipped with nose-wheel tricycle fixed landing gear.

The aircraft is powered with the TEXTRON Lycoming AEIO-360-A1B6 piston air cooled flat 4-cylinder engine with the MTV-9-B-C/C-188-18a hydraulic controlled three-blade constant speed propeller. The engine is not equipped with reducer and is capable for acrobatics and inverted flights. The propeller is made of wood with composite covering. The propeller is capable for acrobatic manoeuvres.

Dimensions	
Span	9.340 m
Length	6.940 m
Height	2.950 m

Table 2-1 Basic dimensions of the Z 242L aircraft

Category	Cent. of gr. (% MAC)	Max. take-off weight (kg)	Max. landing weight (kg)	Max. range of permissible maneuvering load factors (g)
Acrobatic (A)	19.0 - 24.5	970	970	+6.0 ; -3.50
Utility (U)	19.0 - 24.5	1020	1020	+4.4 ; -1.76
Normal (N)	19.0 - 26.0	1090	1050	+3.8 ; -1.52

Table 2-2 Centre of gravity position, weight, manoeuvring load factors

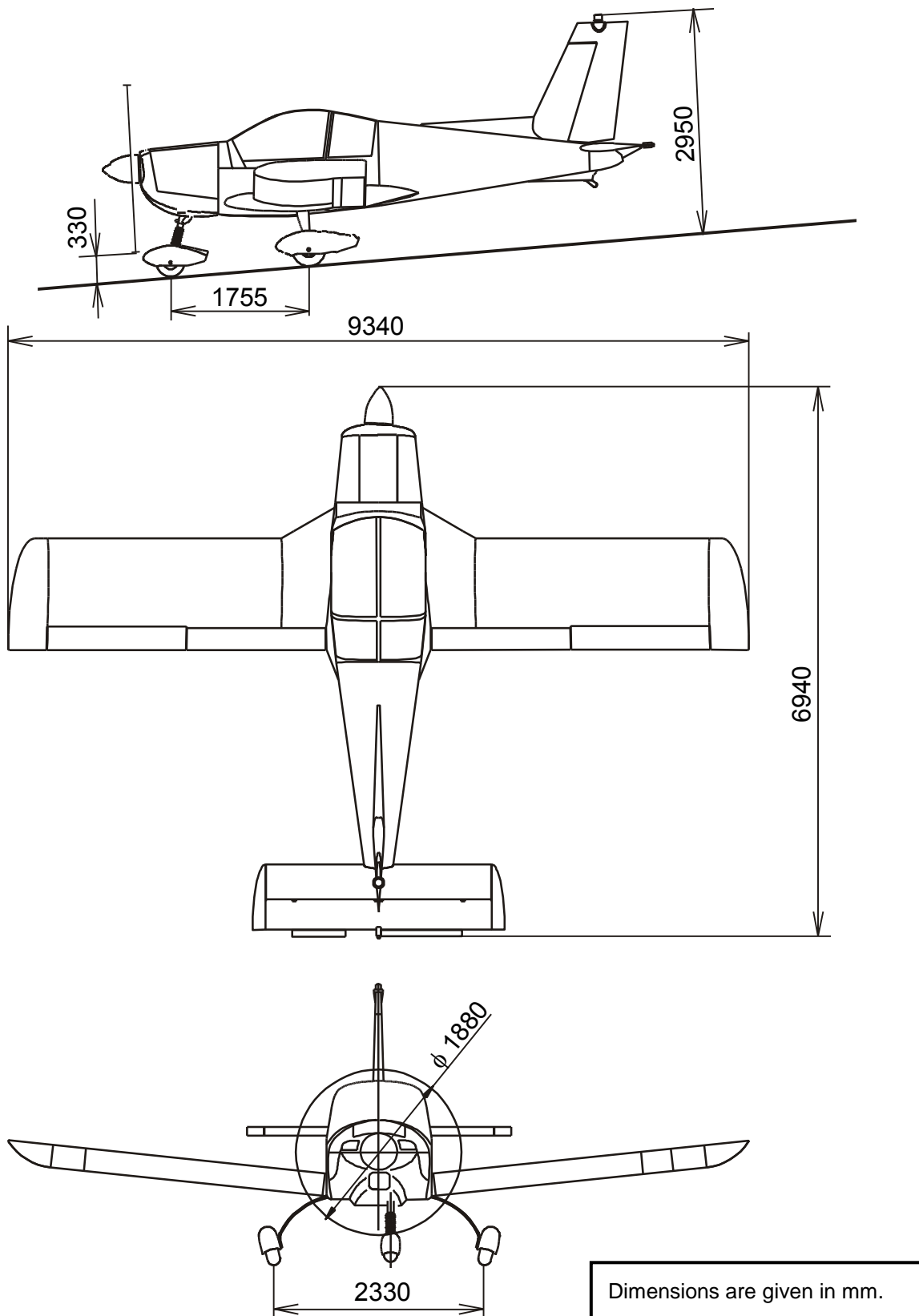

Fig. 2-1 Z 242L aircraft



2.2 Considered spectrum of Z 242L aircraft loading

There are considered following manoeuvring loading spectrums in this report:

- **ZLIN-A** acrobatic spectrum, the loading spectrum was gained experimentally by means of accelerometer AMU1 - see the Z242L-0530 report.
- **CAA-FAA** spectrum, the loading spectrum was gained after consultations between aviation authorities CAA and FAA for common acrobatic operation.
- **ENVELOPE** spectrum, the loading spectrum was gained as a safety envelope from all aircrafts operated by Sault College Aviation Technology. Monitored period is mentioned in the Table No. 1-1.

Loading spectrums

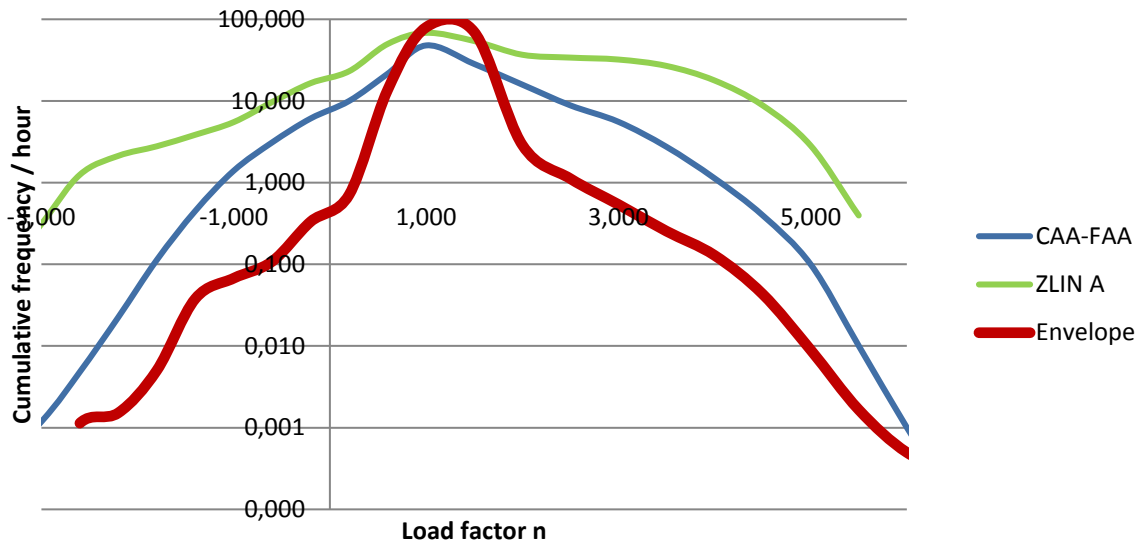

Load factor	Loading spectrums - Cumulative frequency/hour		
	CAA-FAA	ZLIN A	Envelope
-3.800	1.224E-04	1.866E-02	0.000E+00
-3.000	1.185E-03	3.112E-01	2.000E-04
-2.600	4.825E-03	1.250E+00	1.136E-03
-2.200	2.257E-02	2.128E+00	1.519E-03
-1.800	1.131E-01	2.786E+00	5.029E-03
-1.400	4.503E-01	3.855E+00	3.792E-02
-1.000	1.399E+00	5.508E+00	6.760E-02
-0.600	3.109E+00	9.705E+00	1.086E-01
-0.200	6.106E+00	1.652E+01	3.333E-01
0.200	1.000E+01	2.312E+01	7.101E-01
0.600	2.149E+01	4.977E+01	1.361E+01
1.000	4.786E+01	6.823E+01	7.974E+01
1.500	2.841E+01	5.420E+01	7.019E+01
2.000	1.586E+01	3.681E+01	2.907E+00
2.500	8.840E+00	3.396E+01	1.120E+00
3.000	5.562E+00	3.214E+01	5.407E-01
3.500	2.747E+00	2.685E+01	2.548E-01
4.000	1.131E+00	1.782E+01	1.289E-01
4.500	3.985E-01	8.831E+00	4.330E-02
5.000	9.996E-02	2.838E+00	8.958E-03
5.500	1.006E-02	3.963E-01	1.659E-03
6.000	1.006E-03	6.138E-02	4.977E-04
6.500	1.160E-04	0.000E+00	2.841E-04

Table 2-3 Considered spectrum of Z 242L aircraft loading

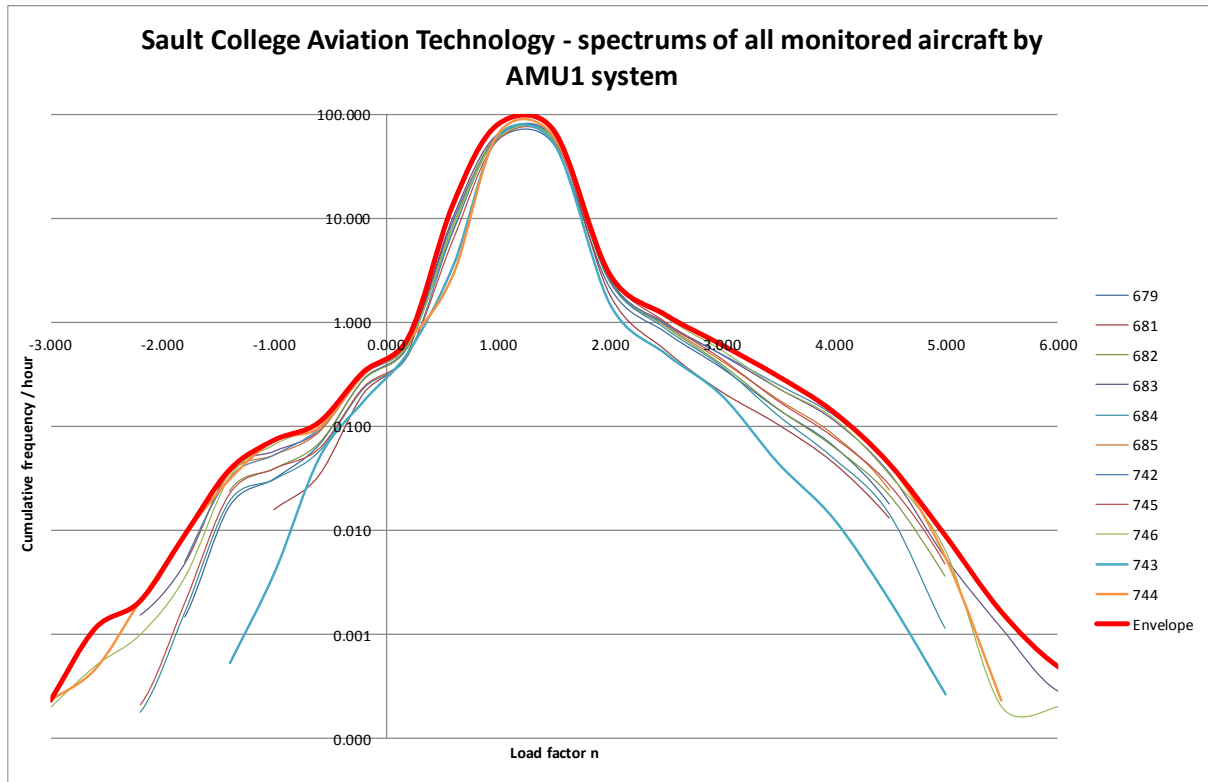

Load factor	Recorded spectrums by AMU1 system - Cumulative frequency/hour											Envelope
	679	681	682	683	684	685	742	743	744	745	746	
-3.000									0.00023		0.000	2.302E-04
-2.600				0.001	0.000				0.00046	0.000	0.001	1.136E-03
-2.200	0.000			0.002	0.000	0.001	0.000		0.00207	0.000	0.001	2.071E-03
-1.800	0.001		0.002	0.005	0.002	0.005	0.005	0.000	0.00897	0.002	0.004	8.974E-03
-1.400	0.017	0.007	0.024	0.038	0.019	0.035	0.032	0.00053	0.03083	0.023	0.033	3.792E-02
-1.000	0.032	0.016	0.039	0.058	0.031	0.053	0.054	0.00394	0.07341	0.040	0.068	7.341E-02
-0.600	0.067	0.034	0.068	0.091	0.058	0.088	0.097	0.05018	0.09734	0.062	0.109	1.086E-01
-0.200	0.287	0.210	0.280	0.316	0.235	0.332	0.333	0.17734	0.31410	0.242	0.331	3.333E-01
0.200	0.609	0.536	0.587	0.640	0.494	0.710	0.644	0.52940	0.67813	0.508	0.639	7.101E-01
0.600	9.586	13.609	8.610	10.548	7.605	12.610	7.878	3.61230	2.88443	6.363	8.652	1.361E+01
1.000	58.177	79.744	63.077	65.679	60.531	77.939	62.281	63.35514	65.23641	57.282	60.904	7.974E+01
1.500	51.805	67.377	59.812	58.104	58.128	70.192	59.938	52.68193	61.91478	56.236	57.879	7.019E+01
2.000	2.186	1.897	2.493	2.520	2.525	2.644	2.603	1.49836	2.83058	2.907	2.849	2.907E+00
2.500	0.807	0.549	0.918	0.983	0.877	0.948	0.958	0.49814	1.17977	1.014	1.120	1.180E+00
3.000	0.367	0.218	0.396	0.489	0.383	0.427	0.497	0.19810	0.60887	0.452	0.541	6.089E-01
3.500	0.148	0.107	0.149	0.233	0.130	0.183	0.255	0.04466	0.30559	0.179	0.237	3.056E-01
4.000	0.065	0.045	0.064	0.114	0.050	0.083	0.129	0.01287	0.13807	0.080	0.120	1.381E-01
4.500	0.018	0.013	0.022	0.035	0.015	0.024	0.043	0.00210	0.04372	0.028	0.034	4.372E-02
5.000	0.002	0.003	0.004	0.005	0.001	0.003	0.009	0.00026	0.00552	0.005	0.006	8.958E-03
5.500			0.000	0.001	0.000		0.002	0.000	0.00023	0.000	0.000	1.659E-03
6.000				0.000			0.000				0.000	4.977E-04
6.500				0.000								2.841E-04

Table 2-4 Recorded spectrums by AMU1 system - Cumulative frequency/hour

3 SAFE FATIGUE LIFE OF THE Z 242L AIRCRAFT

The safe fatigue life calculation was performed according to AFS-120-73-2 and AC23-13A methodology.

Wing of the Z 242L aircraft was loaded by this loading spectrum:

- Manoeuvre + Gust: Envelope, (U, N category)
- Landing: Fig. No.:9 Curve for "Private Trainer", AFS-120-73-2, [2] or [3]
- Taxi: Fig. No.:10R Curve for "All Others (Rev)", AFS-120-73-2, [2] or [3]

The critical point of wings, drawing No. L242.2100/2200 of Z 242L aircraft from the fatigue life point of view is lower duralumin flange close behind the attachment fittings.

Loading at flight as well as at standing on the ground was taken over from the flight measurements of Z 242L aircraft OK-VNP, S/N 0490. Results of stress measurements for the wing of the Z 242L are mentioned in [3].

S-N curves were taken over:

- For duralumin flanges from FAA methodology AFS 120-73-2, [2].
- Fatigue test of main spar of the fuselage frame specimens - Report Z242L-0564, [3].

3.1 The fatigue test of the wing made based on ZLIN-A and ZLIN-N loading spectra

The results of the fatigue test are given in detail in the Z242L-0553 report, [4].

Conclusion:

The result value of Safe Fatigue Life of airframe of the Z 242L aircraft for the ZLIN-A and ZLIN-N manoeuvring spectra is 5500 flight hours, 700 acrobatic hours from it.

3.2 Results of fatigue tests of three main wing spars of the Z 242L aircraft at the CAA-FAA load spectrum

Fatigue tests of three main wing spars of the Z 242L aircraft were made. Results of fatigue tests are given in Report Z 242L-0520, [5].

Conclusion:

The result value of Safe Fatigue Life of airframe of the Z 242L aircraft for the CAA-FAA manoeuvring spectrum is 5500 flight hours without acrobatic limitation.

4 SAFE FATIGUE LIFE OF THE WING

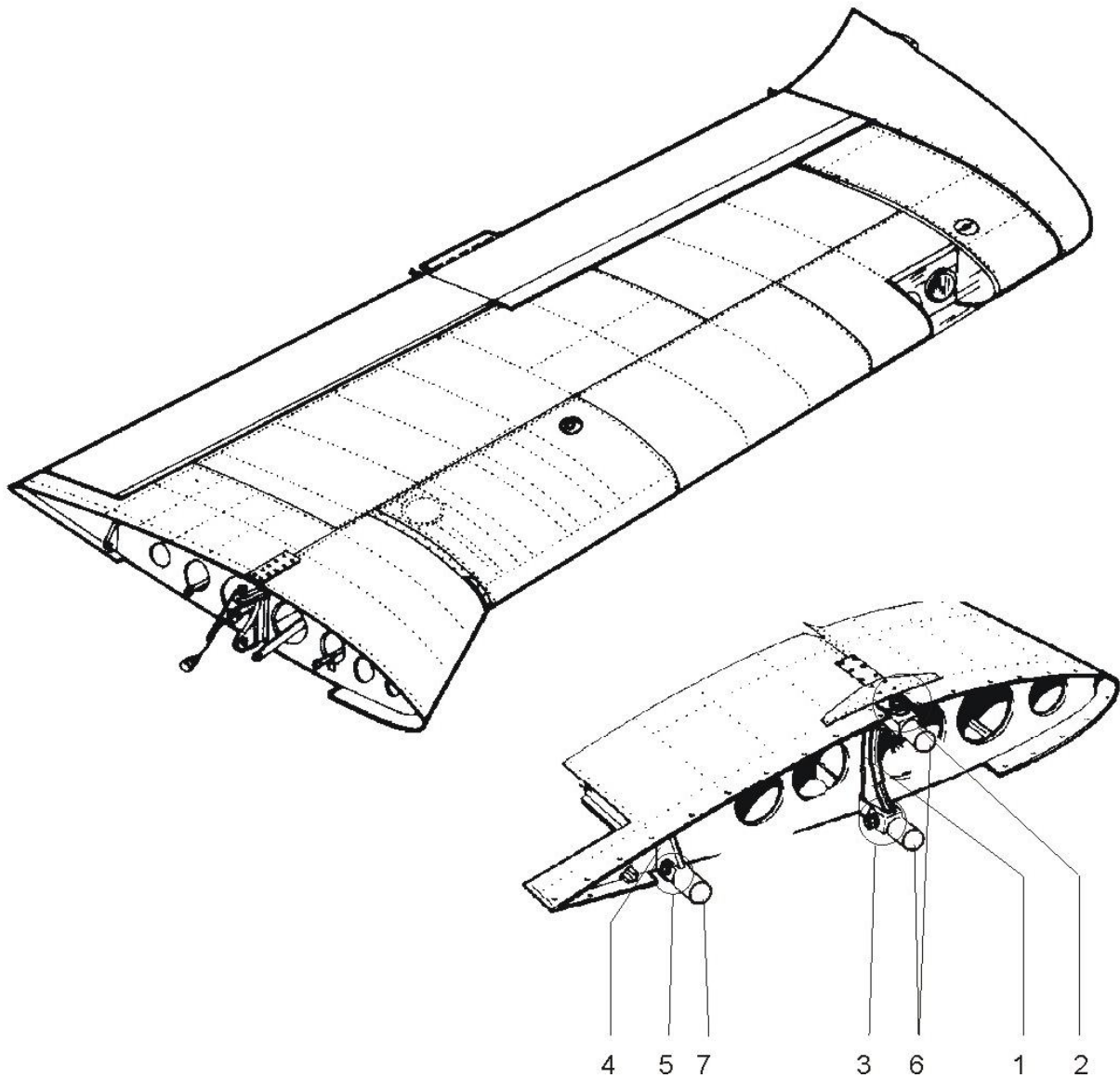

Fig. 4-1 Wing of the Z 242L aircraft

- | | |
|--------------------------------------|--|
| 1 main wing spar | 5 rear wing attachment fitting |
| 2 wing upper attachment fitting | 6 main spar of the fuselage frame |
| 3 wing lower attachment fitting | 7 rear spar of the fuselage frame |
| 4 rear wing spar | |

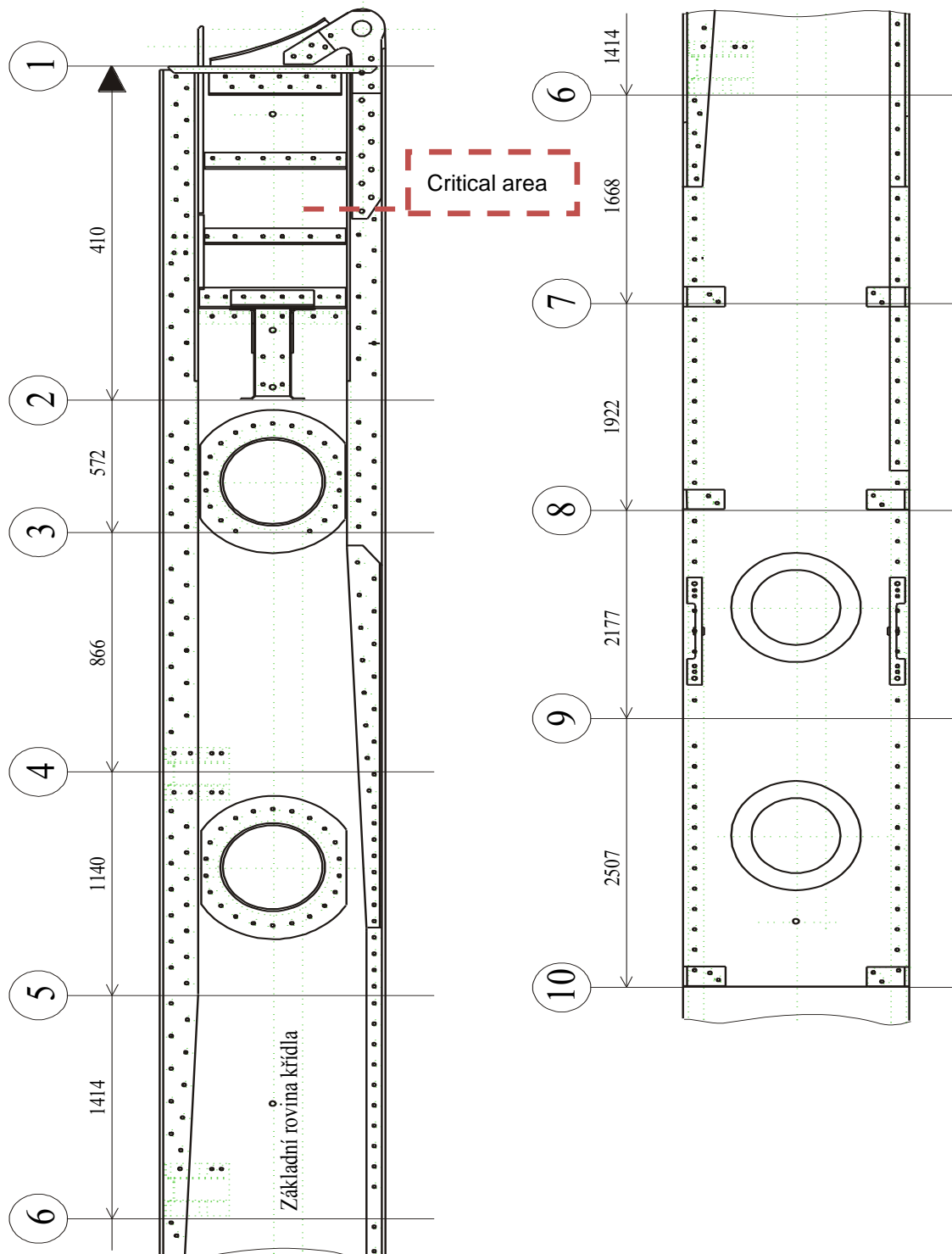

Fig. 4-2 Main wing spar of the Z 242L aircraft

4.1 Stress values in critical section A-A (Category U)

The loading conditions for UTILITY category are recalculated on the base of the maximum take-off weight, Report Z242-0564, [3]. The input values are presented lower:

Loading in flight: $n = 1.0 \text{ g}$ $\sigma_{+1g} = 24.90 \text{ MPa}$ /flange margin/
 Loading at the ground stay: $n = -1.0 \text{ g}$ $\sigma_{-1g} = -7.4 \text{ MPa}$ /flange margin/

Phases of flight	Fatigue damage D_i [1 per flight hour]
Taxi	1.1712E-11
Gust and Manoeuvres	8.6250E-06
Landing – (Impact-Rebound)	1.3561E-08
G-A-G cycle	1.3878E-06
Total fatigue damage D_C	1.0026E-05

Table 4-2 U category operation; fatigue damage caused by ENVELOPE spectrum

$$L_s = 1/D_C = 99\,737 \text{ flight hours}$$

4.2 Stress values in critical section A-A (Category N)

The loading conditions for NORMAL category are recalculated on the base of the maximum take-off weight, Report Z242-0564, [3]. The input values are presented lower:

Loading in flight: $n = +1.0 \text{ g}$ $\sigma_{+1g} = 26.63 \text{ MPa}$ /flange margin/
 Loading at the ground stay: $n = -1.0 \text{ g}$ $\sigma_{-1g} = -8.0 \text{ MPa}$ /flange margin/

Phases of flight	Fatigue damage D_i [1 per flight hour]
Taxi	1.5246E-11
Gust and Manoeuvres	5.9526E-06
Landing – (Impact-Rebound)	1.9071E-08
G-A-G cycle	1.8862E-06
Total fatigue damage D_C	7.8579E-06

Table 4-3 N category operation; fatigue damage caused by Zlin-N spectrum

$$L_s = 1/D_C = 127\,261 \text{ flight hours.}$$

4.3 Safety factor determination

Based on the period of monitoring by AMU1 and results of wing fatigue tests, the safety factor is set to $j_N = 5.0$.

4.4 Safe fatigue life calculation for Canada-Operation loading spectrum

The Safe Fatigue Life of the wing is calculated according lower mentioned formula. For these purposes the Category U, N results are used for the safe fatigue life calculation.

$$L_B = L_S^{(\text{Category U})} / j_N = 99\,737 / 5 = 19\,947 \text{ flight hours.}$$

$$L_B = L_S^{(\text{Category N})} / j_N = 127\,261 / 5 = 25\,452 \text{ flight hours.}$$

Type	S/N	Reg. mark	Flight hrs. (2/2019)	Landings	Monitored by AMU1	Safe-life limit	Possible operation time	Possible total operation time
[-]	[-]	[-]	[Hrs]	[-]	[Hrs]	[%]	[Hrs]	[Hrs]
Z 242L	743	C-GSOP	4993:30	4487	3806:10:00	76.89%	15 338	20 331
Z 242L	744	C-GEER	4598:00	4162	4345:45:00	79.82%	15 922	20 520

Table 4-4 Possible total operational life for Z 242L aircraft wing

Safe fatigue life determination of Z 242L aircraft wing

Conclusion:

Based on executed fatigue tests and calculations and with respect to other groups of airframe of the aircraft, we appoint the value of safe fatigue life for the wing of the Z 242L aircraft to:

LB= 11 000 flight hours.

Other procedures:

Proposed regular checks according to: Maintenance Manual for aircraft Z 242L - Part I, II.

Replacement:

Conic pins and bushings for attaching the wings to the fuselage - after every 6000 flight hours.

5 SAFE FATIGUE LIFE OF MAIN SPAR OF THE FUSELAGE FRAME

The main spar of the fuselage frame is a complicated weldment that is made of steel tubes from L-CM3 material according to valid regulations and procedures. There are installed upper and lower attachments of the wing, attachments of the front seats and attachments of the main landing gear on the main spar of the fuselage frame. The lower flange of the main spar is equipped with pressure probe which signalises to the pilot contingent appearance of a crack on the flange.

Frame of the fuselage including main spar is shown on the Fig. 5-1.

Numbers of drawings and values of diameter and thickness of the upper and lower flange of the main spar of the fuselage frame for the Z 42 series are given in the Table 5-1.

Aircraft	Main spar	Upper flange		Lower flange	
		Drawing No.	Drawing No.	Tube Ø	Drawing No.
Z42 to S/N 0059 including	Z42.1110	Z42.1111-00.17	Tube 55x3.0	Z42.1112-00.17	Tube 50x3
Z42 from 3 rd series from S/N 0060	M42.1110	M42.1111-00.17	Tube 55x3.5	M42.1112-00.17	Tube 50x4
Z 142	M42.1110	M42.1111-00.17	Tube 55x3.5	M42.1112-00.17	Tube 50x4
Z 142C	M42.1110	M42.1111-00.17	Tube 55x3.5	M42.1112-00.17	Tube 50x4
Z 242L	L242.1110	M42.1111-00.17	Tube 55x3.5	M42.1112-00.17	Tube 50x4

Table 5-1 Drawings numbers and parameters of the upper and lower flange of the main spar of the fuselage frame

	C	Mn	Si	Cr	Mo	Ni	Cu	P	S
Chemical composition (%)	0.22 to 0.29	0.50 to 0.80	0.17 to 0.37	0.90 to 1.20	0.15 to 0.25	max. 0.30	max. 0.25	max. 0.030	max 0.030
Permitted deviations of chemical composition (%)	±0.01	±0.05	+0.05 -0.02	+0.10 -0.05	+0.07 -0.03				

Table 5-2 Chemical composition of L-CM3 material according to ONL 2100

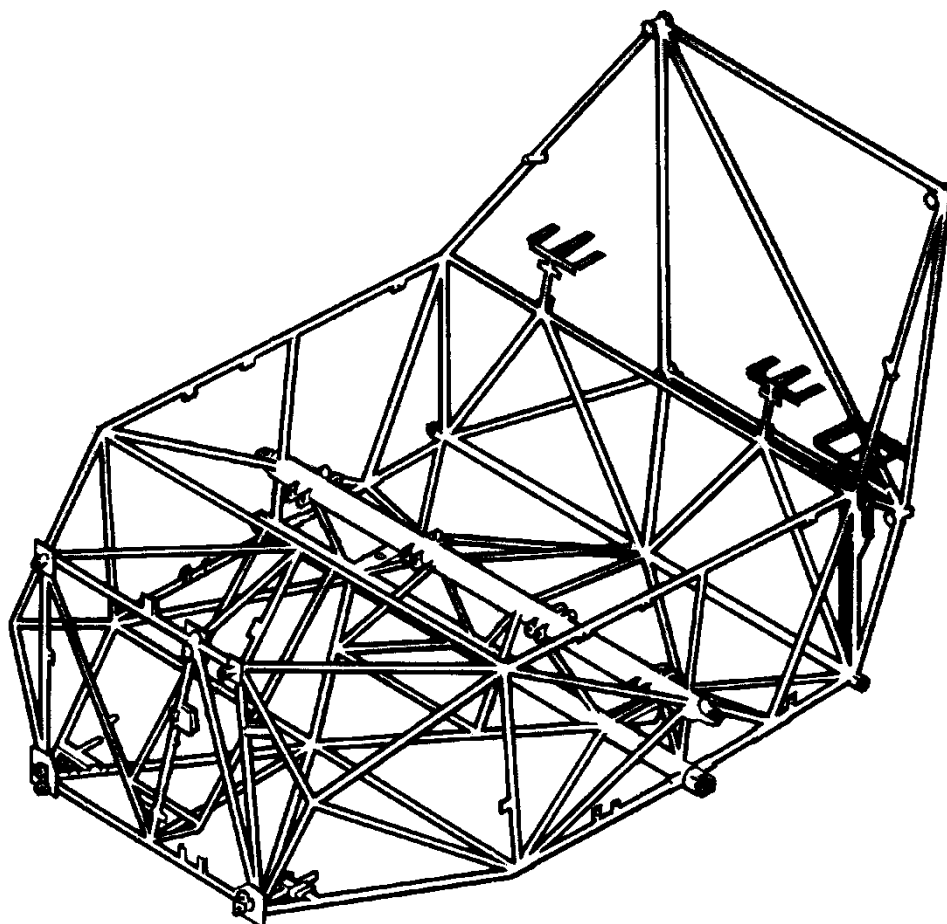

Fig. 5-1 Fuselage frame of the Z 242L aircraft

5.1 Stress values in critical section A-A (Category U)

The loading conditions for UTILITY Category are recalculated on the base of the maximum take-off weight, Report Z242-0564. The input values are presented lower:

Loading in flight: n= +1 g $\sigma_{+1g} = 57.9 \text{ MPa}$
 Loading at the ground stay: n= -1 g $\sigma_{-1g} = -2.2 \text{ MPa}$

Phases of flight	Fatigue damage D_i [1 per flight hour]
Taxi	0.0000E+00
Gust and Manoeuvres	1.8959E-06
Landing – (Impact-Rebound)	3.6771E-09
G-A-G cycle	2.6881E-07
Total fatigue damage D_C	2.1684E-06

Table 5-5 U category operation; fatigue damage caused by ENVELOPE spectrum

$L_s = 1 / D_c = 461\ 180$ flight hours.

5.2 Stress values in critical section A-A (Category N)

The loading conditions for NORMAL Category are recalculated on the base of the maximum take-off weight, Report Z242-0564. The input values are presented lower:

Loading in flight: n= +1 g $\sigma_{+1g} = 62.6 \text{ MPa}$
 Loading at the ground stay: n= -1 g $\sigma_{-1g} = -2.3 \text{ MPa}$

Phases of flight	Fatigue damage D_i [1 per flight hour]
Taxi	0.0000E+00
Gust and Manoeuvres	1.7225E-06
Landing – (Impact-Rebound)	4.8278E-09
G-A-G cycle	3.4516E-07
Total fatigue damage D_C	2.0725E-06

Table 5-5 N category operation; fatigue damage caused by Zlin-N spectrum

$L_s = 1 / D_c = 482\ 507$ flight hours.

5.3 Safety factor determination

According to AFS-20-73-2 methodology safety factor $j_N = 7 - 8$ is specified for Safe Fatigue Life calculation. Based on the origin of S-N curve (samples) and the mentioned methodology AC23-13A, it is recommended to choose value of $j_N = 8.0$ for standard cases.

5.4 Safe fatigue life calculation for ENVELOPE loading spectrum

The safe fatigue life of the fuselage frame is calculated according lower mentioned formula. For these purposes the Category U, N results are used for the safe fatigue life calculation.

$$L_B = L_S^{(\text{Category U})} / j_N = 461\,180 / 8.0 = 57\,647 \text{ flight hours.}$$

$$L_B = L_S^{(\text{Category N})} / j_N = 482\,507 / 8.0 = 60\,313 \text{ flight hours.}$$

5.5 Safe fatigue life determination of the fuselage frame main spar

Conclusion:

Based on executed calculation and with respect to other groups of airframe of the aircraft, we appoint the value of Safe Fatigue Life for the main spar of the fuselage frame to:

$$L_B = 11\,000 \text{ flight hours.}$$

Other procedures:

Proposed regular checks according to: Maintenance Manual for aircraft Z 242L - Part I, II.

System function check:

- Lower flange pressure following-up - every 500 flight hours or once a year.

Replacement of the pressure probe in system:

- Lower flange pressure following-up - after every 6000 flight hours.

6 SAFE FATIGUE LIFE OF THE REAR PART OF THE FUSELAGE AND BOLTS /Z42.1300-00.11/, CONNECTING CENTRAL AND REAR PART OF THE FUSELAGE

Fatigue life was appointed based on fatigue tests of fuselage rear part including connecting bolts – see Report Z242L-009, [6]. Conclusion of the fatigue tests analysis is given in Report Z242L-0564 Appendix No. 1, [3].

Rear part of the fuselage is shown on the Fig. 6-1 and connection of front and rear part of the fuselage is shown on the Fig. 6-1.

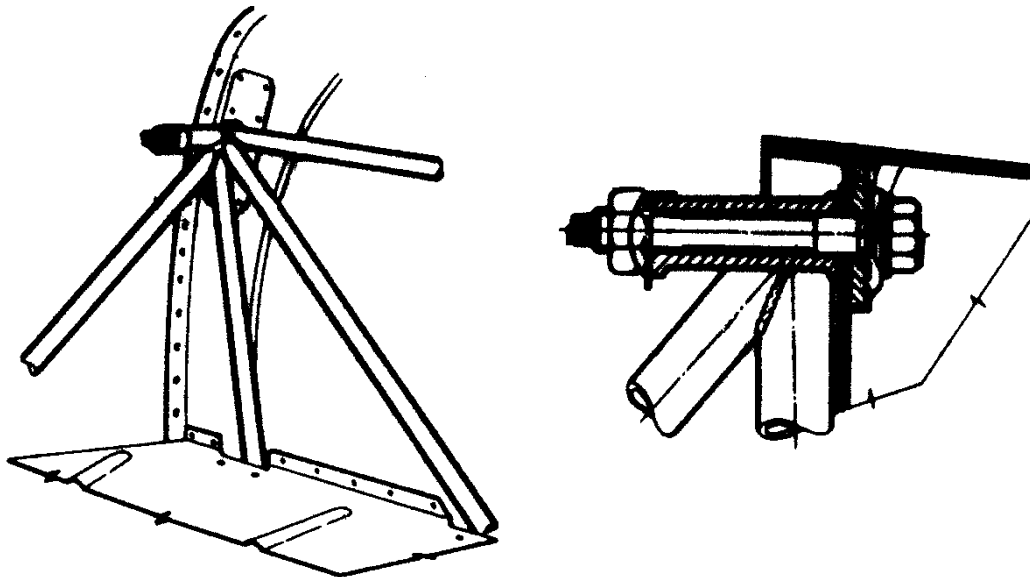

Fig. 6-1 Connection of fuselage front and rear part of the Z 242L aircraft

Conclusion:

We appoint the value of Safe Fatigue Life of bolts connecting central and rear part of the fuselage, with respect to present maintenance system to:

LB= 6 000 flight hours.

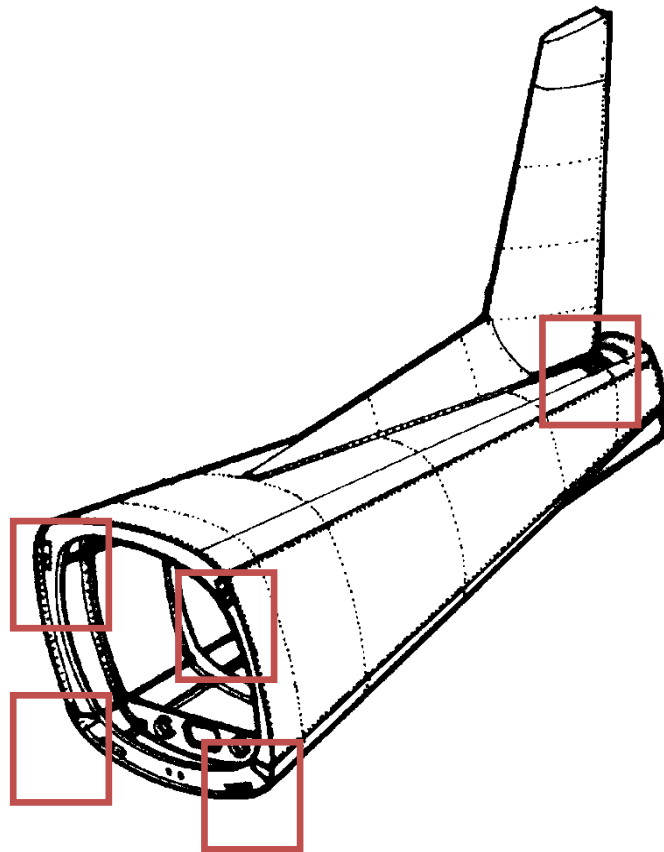

Fig. 6-2 Fuselage rear part of the Z 242L aircraft with market areas for visual inspection check

The Safe Fatigue Life of rear part of the fuselage will be secured with regular inspections and repairs in operation in accordance with specified maintenance system.

Conclusion:

We appoint the safe fatigue life value of rear part of the fuselage to:

LB= 11 000 flight hours.

Other procedures:

Proposed regular inspections acc. to: Maintenance Manual Z 242L - Part I, II.

Replacement of the bolts connecting central and rear part of the fuselage:
- after every 6000 flight hours.

Visual inspection checks for crack, damage, deformation; see Fig. 6-2
- after every 500 flight hours.

7 SAFE FATIGUE LIFE OF TAIL SURFACES

Safe Fatigue Life of tail surfaces was specified neither by calculation, nor by test. Safe Fatigue Life of tail units will be secured by regular checks and contingent repairs in operation in accordance with specified maintenance system.

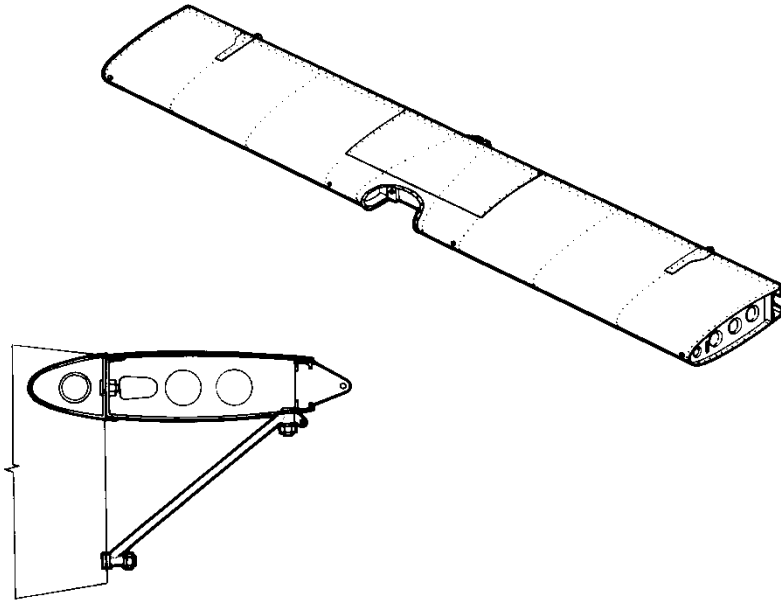

Fig. 7- 1 Stabilizer including supports

Conclusion:

We appoint the value of Safe Fatigue Life of tail surfaces according to the above-given and with respect to other groups of primary frame to:

LB= 11 000 flight hours.

Other procedures:

Proposed regular checks according to: Maintenance Manual for Z 242L - Part I, II

Replacement:

- Stabilizer supports replacement including connecting bolts - after every 6000 flight hours.
- Connecting bolts attachment fittings of the stabilizer - after every 6000 flight hours.

8 SAFE FATIGUE LIFE OF ENGINE MOUNT

Safe Fatigue Life of engine mount was specified neither by calculation, nor by test. Safe Fatigue Life of engine mount will be secured by regular checks and repairs in operation in accordance with specified maintenance system.

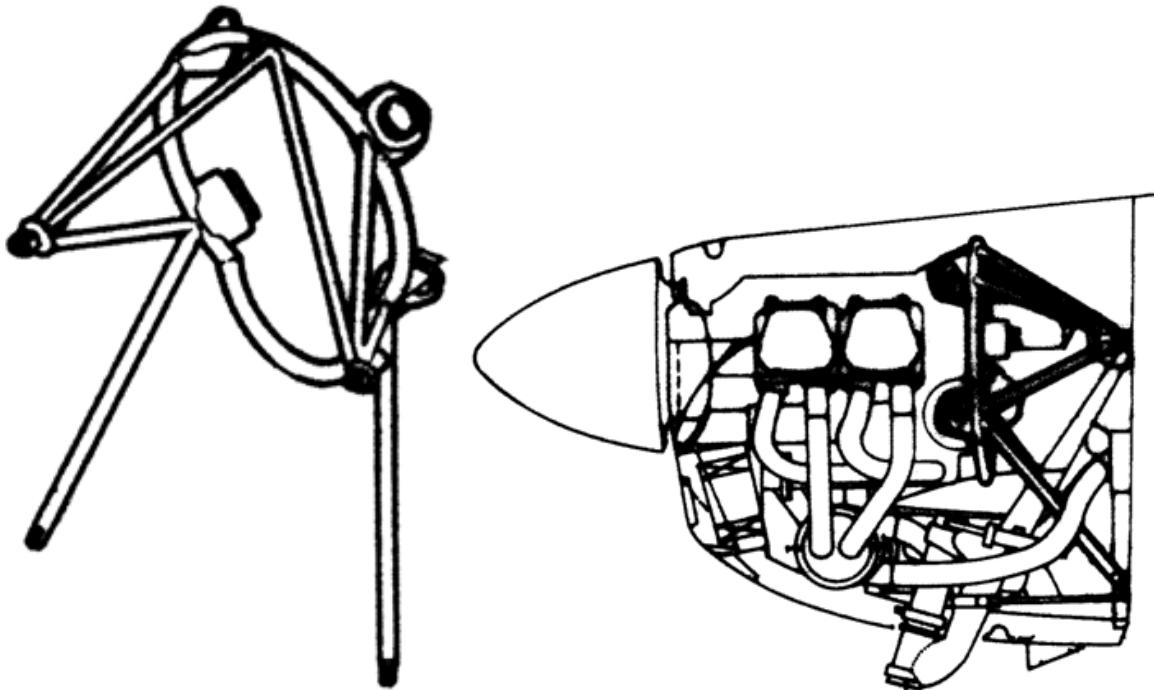

Fig. 8-1 Engine mount including engine clamping is shown on the

Conclusion:

We appoint the value of Safe Fatigue Life value of engine mount according to the above-given to:

LB= 6 000 flight hours.

Other procedures:

Proposed regular checks according to: Maintenance Manual for aircraft Z 242L - Part I, II.

Replacement:

- Engine mount - after every 6000 flight hours.

9 REGULAR REPLACEMENTS OF PARTS OF THE Z 242L AIRCRAFT

- Main landing gear 2500 flight hours (11000 landings)
- Main landing gear hinges screw 2500 flight hours (11000 landings)
- Nose landing gear (without wheel) 3500 flight hours (15000 landings)

10 AIRCRAFT PARTS AT WHICH OVERHAUL IS MADE

- Engine according to engine manufacturer data
- Engine aggregates together with engine
- Magnetos according to engine manufacturer data
- Propeller according to propeller manufacturer data
- Propeller governor according to governor manufacturer data
- Nose landing gear (without wheel) according to manufacturer data

11 INSTRUMENTS AND AGGREGATES

Instruments and aggregates are kept “on condition”. Maintenance and checks are performed according to Maintenance Manual Z 242L - Part I, II.

12 OPERATION INFORMATION ANALYSIS

From the accessible information about the Z 242L aircraft operation in the aviation school (SCAT) results that there arose no significant failures of primary structure of the aircraft caused by operation loading of the aircraft. Increased number of defects was recorded at the brake system, propeller including propeller blades and flaps system.

13 CONCLUSION

The Z 242L aircraft is designed in the category A, U and N in according to FAR Part 23 - Amdt. 23-36 inclusive. The aircraft is intended for basic and advanced training or acrobatic training and practice.

Calculations and analyses of primary structure of Z 242L aircraft were executed in accordance with AFS-120-73-2 and AC23-13A methodologies and according to FAR 23 Amdt. 23-36 inclusive. The critical place from the fatigue life point of view is on the lower duralumin flange, close behind the attachments. Loading at flight as well as at standing on the ground was taken-over from flight measurements of the Z 242L aircraft. The S-N curves were taken-over for duralumin flanges from the FAA AFS-120-73-2 methodology, for the main spar of the fuselage frame from the fatigue test of Z 242L main spar of the fuselage frame specimens.

All SCAT aircraft are monitored for the long time by the AMU1 system. The envelope of all AMU1 records was used as an input source for the aircraft prolongation.

From the calculations and fatigue tests follows that aircraft Z 242L, S/N 0743 and S/N 0744 operated in aviation school SCAT can be safely operated in category U and N up to 11 000 flight hours.

The Safe Fatigue Life value of the aircraft Z 242L, S/N 0743 and S/N 0744 primary structure is determined with respect to operation in SCAT to:

LB = 11 000 flight hours.



APPENDIX NO. 1

**TECHNICAL COMMISSION REPORT BASED ON THE REQUEST TO INCREASE
THE OPERATIONAL LIFE TIME UP TO 11 000 FLIGHT HOURS
(S/N 0743)**



ZLIN AIRCRAFT a.s. Letiste 1887, 765 02 Otrokovice, Czech Republic Design Organization Approval Certificate EASA.21J.110								
Protocol from the aircraft inspection conducted by the Technical Commission								
Protocol No. 2/2019			Type: Z 242L			Owner: Sault College, Canada		
Registration mark	S/N	Year of production	TTSN	TLSN	TT from the last inspection	TL from the last inspection	Last Overhaul	
							Number of Rev. C	Date
C-GSOP	0743	2000	5 067.5	4 555	N/A	N/A	N/A	N/A

Based on the service order from the owner of the aircraft, Technical Commission of aircraft Manufacturer - ZLIN AIRCRAFT a.s. Otrokovice - performed technical inspection of the airframe of the above specified aircraft.

After removing the failures stated in this Protocol, the Technical Commission recommended to:

Technical Commission conducted technical inspection based on the request to increase the life time of the aircraft up to 11 000 flight hours.

Sault College, FEB 20, 2019

Pavel Mužný
Technical Commission

No.	Structural group and List of Failures - Concise description	
1.	Fuselage	L242.1000-00.00
	OK	
2.	Carrier system	L242.0200-00.00
	OK	
3.	Empennage	L242.3000-00.00
	OK	
4.	Control systems	L242.4000-00.00
	OK	
5.	Landing gear	L242.5000-00.00
5.1	Nose wheel: lock washer lock tab to be seated tighten in notch of nut.	
	<i>Nose wheel lockwasher tightened in knotch of nut</i>	
6.	Engine installation	L242.6000-00.00
	OK	
7.	Engine systems	L242.7000-00.00
	OK	



8.	Cabin equipment	L242.8100-00.00	
			OK
9.	Board equipment; Cabin ventilation and rating	L242.8200-00.00, L242.8300-00.00	
9.1	Air vent drain hose not connected to drain fitting at belly panel.		
			Air vent drain hose connected to drain fitting at belly panel.
10.	Electrical system	L242.8500-00.00	B.T Feb 20/19
			OK
11.	Radio Equipment	L242.8600-00.00	
			OK
12.	Electrical Lighting	L242.8900-00.00	
			OK

Main spar pressure 210 kPa

A	Failures which must be removed No.:
	5.1, 9.1
B	Failures which are recommended to removed No.:
	N/A
C	Failures which hasn't influence to airworthy No.:
	N/A

The failures have been introduced to Mr. Rick Houle

DEFECTS/FAILURES 5.1 + 9.1 REPAIRS.
REF. WO# 06395





APPENDIX NO. 2

TECHNICAL COMMISSION REPORT BASED ON THE REQUEST TO INCREASE THE OPERATIONAL LIFE TIME UP TO 11 000 FLIGHT HOURS (S/N 0744)



ZLIN AIRCRAFT a.s. Letiste 1887, 765 02 Otrokovice, Czech Republic Design Organization Approval Certificate EASA.21J.110								
Protocol from the aircraft inspection conducted by the Technical Commission								
Protocol No. 1/2019			Type: Z 242L			Owner: Sault College, Canada		
Registration mark	S/N	Year of production	TTSN	TLSN	TT from the last inspection	TL from the last inspection	Last Overhaul	
							Number of Rev. C	Date
C-GERR	0744	2000	4 658.0	4 220	658.4	641	2	09JUN2017

Based on the service order from the owner of the aircraft, Technical Commission of aircraft Manufacturer - ZLIN AIRCRAFT a.s. Otrokovice - performed technical inspection of the airframe of the above specified aircraft.

After removing the failures stated in this Protocol, the Technical Commission recommended to:

Technical Commission conducted technical inspection based on the request to increase the life time of the aircraft up to 11 000 flight hours.

Sault College, FEB 19, 2019

Pavel Mužný
Technical Commission

No.	Structural group and List of Failures - Concise description	
1.	Fuselage	L242.1000-00.00
	OK	
2.	Carrier system	L242.0200-00.00
2.1	R/H wing: Rivet missing on doubler located on aft spar under "walking" area of wing <i>RIVET REPLACED 2/19/19 Ben Collins</i>	
3.	Empennage	L242.3000-00.00
3.1	Stabilizer: L/H + R/H attach point tapered shim washer installed with taper positioned incorrectly tapered shim washers removed and repositioned. New 16x16 washers installed. 2/19/19 Jaylee	
4.	Control systems	L242.4000-00.00
	OK	
5.	Landing gear	L242.5000-00.00
	OK	
6.	Engine installation	L242.6000-00.00
	OK	
7.	Engine systems	L242.7000-00.00
7.1	Fuel selector valve: Sector control rod missing cotter pin <i>Cotter pin installed. A.T. Feb 19/19</i>	



8.	Cabin equipment	L242.8100-00.00
	OK	
9.	Board equipment; Cabin ventilation and rating	L242.8200-00.00, L242.8300-00.00
	OK	
10.	Electrical system	L242.8500-00.00
	OK	
11.	Radio Equipment	L242.8600-00.00
	OK	
12.	Electrical Lighting	L242.8900-00.00
	OK	

Main spar pressure 210 kPa

A	Failures which must be removed No.:
B	Failures which are recommended to removed No.:
	N/A
C	Failures which hasn't influence to airworthy No.:
	N/A

The failures have been introduced to Mr. Rick Houle

DEFECTS/FAILURES CORRECTED IS #2.1, 3.1+7.1

LITERATURE

- [1] Bělohradský, T.; Růžička, P.; Z 242L Assessment Report from point of view of the Safe Fatigue Life of 11 000 flight hours - Sault College Aviation Technology operation; 26. 9. 2003; Report Z242L-0554.
- [2] Report No. AFS-120-73-2; Fatigue Evaluation of Wing and Associated Structure on Small Airplanes - FAA, May 1973.
- [3] Bělohradský, T.; Carbol, V.; Toteck, D.; Evaluation report for Z42 series aircrafts from the safe-life point of view 5500 flight hours and possible intensive aerobatics usage, aircrafts equipped by strengthened wings; 28. 11. 2007; Report Z242L-0564.
- [4] Bělohradský, T.; Růžička, P.; Final report concerning evaluation of Z242L wing fatigue test; 30. 6. 2003; Report Z242L-0553.
- [5] Bělohradský, T.; Definition of basic fatigue life for Z242L aircraft; October 1997; Report Z242L-0520.
- [6] Fišer, J.; Safe fatigue life of the fuselage tail part and of the joint of the fuselage tail and middle parts; 29. 9. 1967; Report Z242L-009.
- [7] Tománek, St.; Bělohradský, T; Z 242L Assessment Report - Aircraft Safe Life prolongation up to 18 000 flight hours Sault College Aviation Technology; 5. 4. 2011; Report Z242L-0567.
- [8] Bělohradský, T; Z 242L Assessment Report - Aircraft Safe Life prolongation up to 18 000 flight hours Sault College Aviation Technology; 10.10. 2012; Report Z242L-0571.
- [9] Bělohradský, T; Z 242L Assessment Report - Aircraft Safe Life prolongation up to 18 000 flight hours Sault College Aviation Technology; 01.06. 2014; Report Z242L-0572.
- [10] Bělohradský, T; Z 242L Assessment Report - Aircraft Safe Life prolongation up to 18 000 flight hours Sault College Aviation Technology; 15.08. 2017; Report Z242L-0573.
- [11] Bělohradský, T; Z 242L Assessment Report - Aircraft Safe Life prolongation up to 18 000 flight hours Sault College Aviation Technology; 22.10. 2018; Report Z242L-0574.